

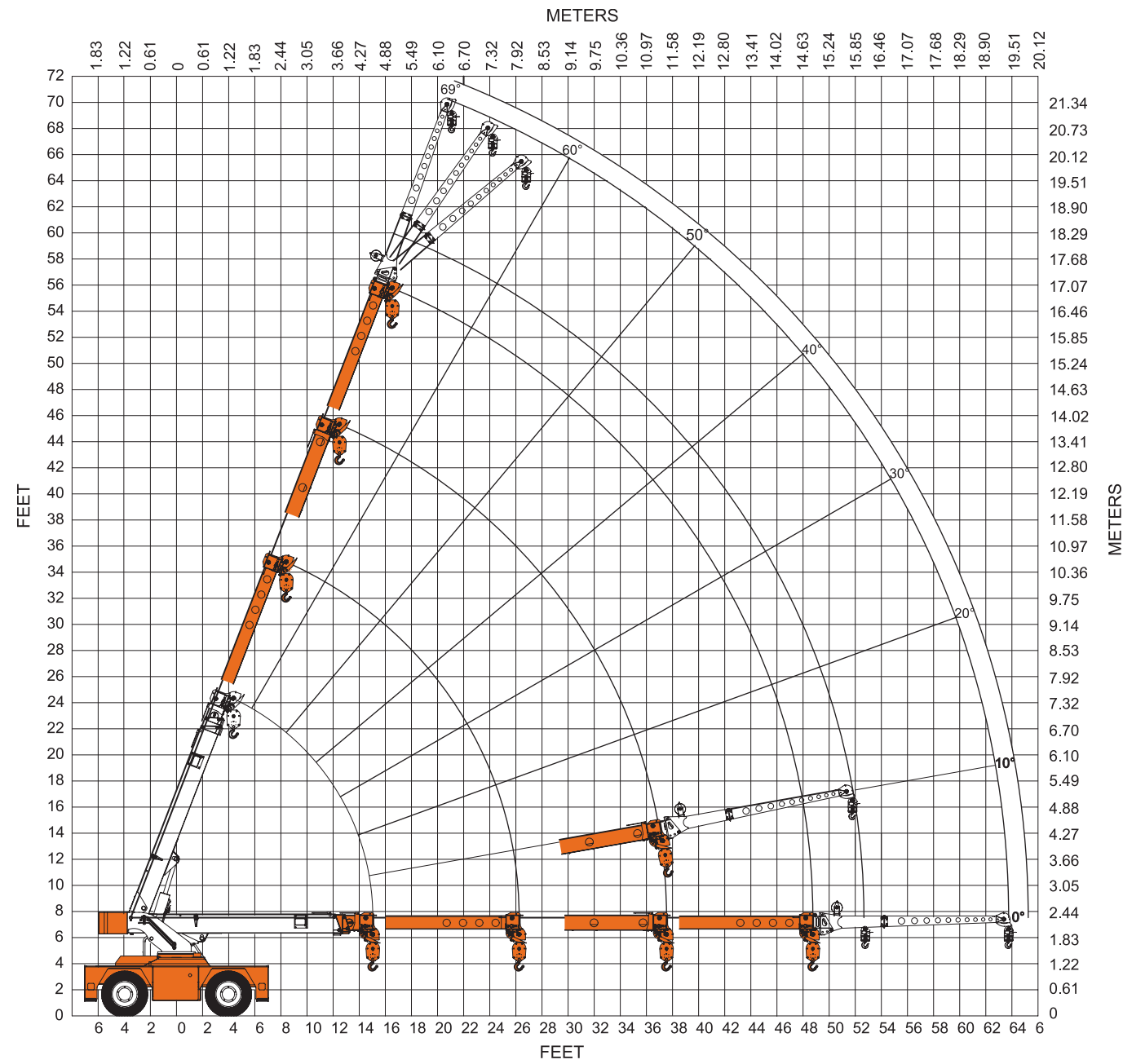

Range Chart



5540F 3 SECTION and 4 SECTION BOOMS WITH 15' (4.6 M) BOOM EXTENSION

Manitowoc
Crane Group
Manitowoc Crane Group - Americas
Shady Grove, Pennsylvania Facility
Tel: [(Int + 001) 717 597 8121]
Fax: [(Int + 001) 717 597 4062]
www.manitowoccrane.com

Constant improvement and engineering progress make it necessary that we reserve the right to make specification, equipment, and price changes without notice. Illustrations shown may include optional equipment and accessories, and may not include all standard equipment.

SHUTTLELIFT®
Carrydeck®
Industrial Cranes

MODEL
5540F
15 TON (13 600 KG)

